

* EXAMPLE BASED ON
35 ROOMS AND
5,528NSF RESIDENTIAL

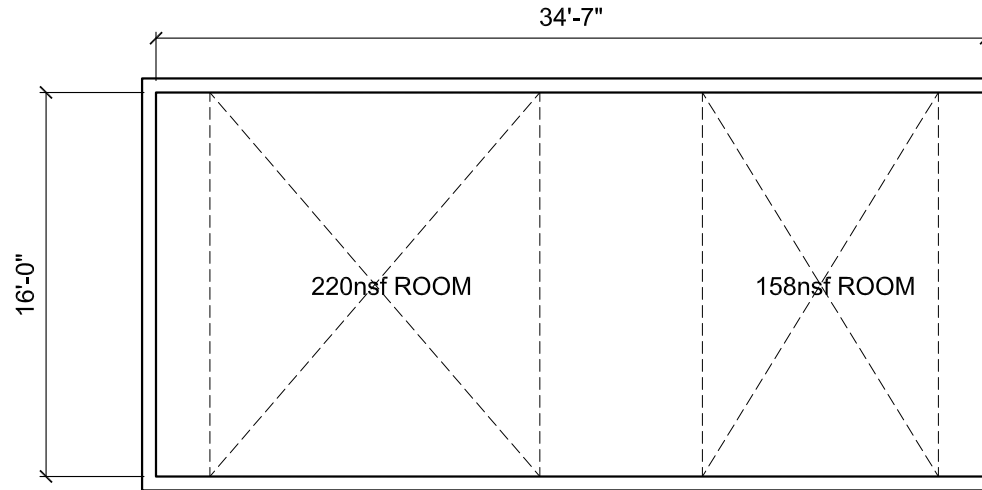

CB 118201
5,528 NSF SLEEPING ROOMS
10% COMMON AREA REQ'D = 553sf
ALL REQ'D TO BE INTERIOR
REDUCES UNIT COUNT BY 4
(ASSUMING 158sf ROOM)
REDUCES UNIT COUNT BY 3
(ASSUMING 220sf ROOM)

EXTERIOR AMENITY AREA REQUIREMENT
LR ZONES: 25% LOT AREA =
4,995SF x 0.25 = 1,250sf

TOTAL AMENITY = 1,803sf

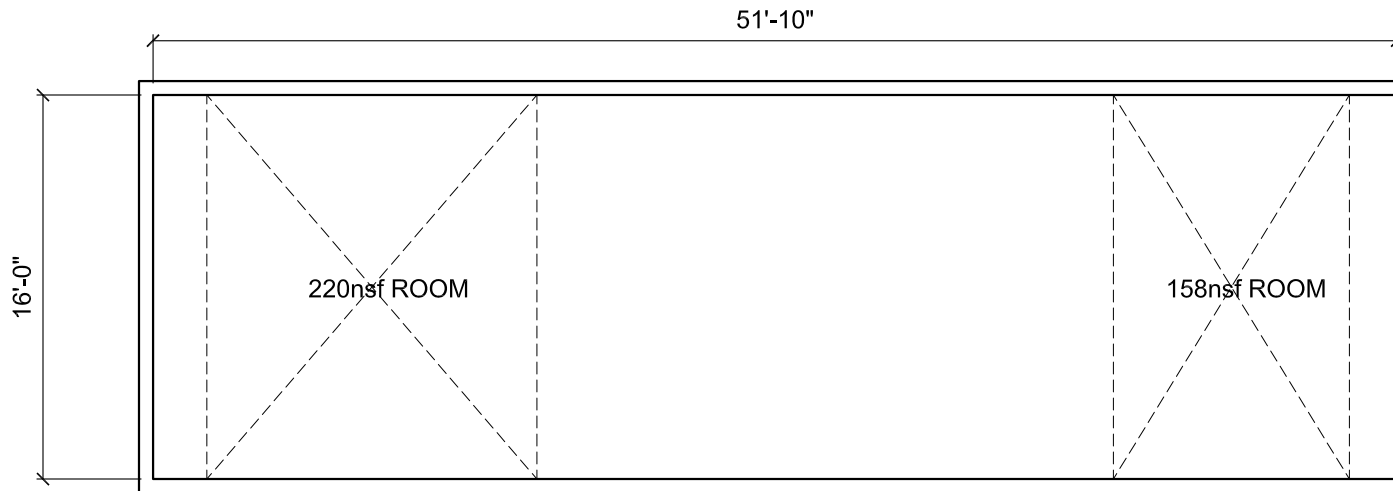

AMENDMENT 5
5,528 NSF SLEEPING ROOMS
15% COMMON AREA REQ'D = 829sf
ALL REQ'D TO BE INTERIOR
REDUCES UNIT COUNT BY 6
(ASSUMING 158sf ROOM)
REDUCES UNIT COUNT BY 4
(ASSUMING 220sf ROOM)

EXTERIOR AMENITY AREA REQUIREMENT
LR ZONES: 25% LOT AREA =
4,995SF x 0.25 = 1,250sf

TOTAL AMENITY = 2,079sf

CB 118201
SEPTEMBER 21, 2014

AMENDMENT #5
SCALE: 1/8" = 1'-0"
SHW#:

CONGREGATE AMENITY AREA

S+HWorks
ARCHITECTURE & DESIGN

p 206-329-1802 e info@s-hw.com w s-hw.com
1101 E. Pike Street #200 | Seattle WA 98122

© 2014 S+HWorks, LLC